



VIDISTAR  
INDOQUIP  
PRADANA  
Specialized in Power Machinery



# PORTABLE

# SCREW COMPRESSOR

## CF750M-7

## SERIES



**AIR PRESSURE: 7 bar**

**FAD: 750 CFM / 21.2 m<sup>3</sup>/min**

### Main Improvements:

#### Availability for wide application

CFAIR model is line up to suit a wide range of applications such as pneumatic tools drilling and blasting.

#### Easy Starting in Cold Weather

This compressor is superior in cold weather starting.

#### Meters with Luminous Lights

Meters on operation panel are equipped with luminous light.

#### Reliable Warning Signal

Warning signals have luminiscent diode and so become more reliable.

#### Double Element Air Cleaner

Double element air cleaner prevents dust from entering when replacing element.

#### Easy Cleaning of Cooling System

This compressor is so designed that the interiors of radiator and oil cooler and also fuel tank can be easily and quickly clean

**HANGZHOU CAIFULL PRECISION MACHINERY CO.LTD**

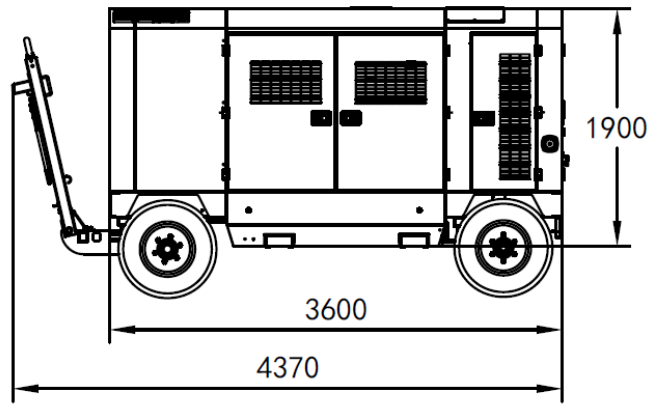
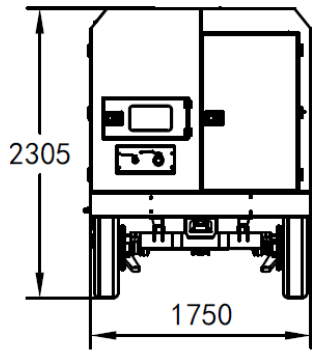

### COMPRESSOR

Type	Rotary twin screw, single stage, oil-cooled
Free air delivery	21.2 m <sup>3</sup> /min(750 cfm)
Working pressure	7 bar (101.5 psi)
Unloader	Suction port closing in connection with stepless speed regulator
Lubrication system	Forced lubrication by compression pressure
Driving system	Direct coupling with rubber
Oil cooling	Air-cooled
Air cleaner	Dry paper filter type

### OIL SEPARATOR-RECEIVER TANK

Type	Vertical, cylindrical, full-welded
Shell dia	450 mm
Shell length	1161 mm
Capacity	160 L
Max. working pressure	1.58MPa
Hydraulic test pressure	2.37MPa
Air outlet valve	1pc x 3 /4" + 1pc 2"
Recommend Oil type	#46

### DIESEL ENGINE

Model	CUMMINS 6CTA8.3-C260
Type	Water-cooled, 4-cycle, Direct-Injection, Turbo-Charged type
No. Of cylinders	6
Bore x stroke	114 mm x 135 mm
Total displacement	8.3 liters
Compression ratio	17.3 : 1
Rated output	194 kW( 260HP ) 2,200rpm
Max. torque	1135 N.m/approx. 1,500rpm
Governor	Mechanical
Alternator	DC28V
Starting motor	DC24V
Battery	120AH X 2 pcs, 580CCA
Air cleaner	Two-stage dry type

### INSTRUMENTS & GAUGES

#### EMERGENCY STOP DEVICES

- Oil pressure switch
- Engine coolant temperature switch
- Discharge air temperature switch
- Compressor oil temperature switch
- Engine speed down switch

#### GAUGES

Air Pressure gauge	Tachometer
Fuel level gauge	Engine oil pressure
Stop button	Engine coolant temp
Starter switch	Discharge air temp
Starting Loader	Discharge air pressure
	Hourmeter

### LIQUID CAPACITY

Fuel tank capacity	400 liters
Engine oil capacity	18 liters
Coolant capacity	55 liters
Compressor oil capacity	105 liters

### DIMENSIONS & WEIGHT

L x W x H	4370 x 1750 x 2305 mm
Weight	4400 Kg
20ft container	1 sets
40HQ container	3 sets



#### INDONESIA DEALER: PT VIDISTAR INDOQUIP PRADANA

Plaza Summarecon Bekasi, Jl. Bulevar Ahmad Yani Kav 01, Level 7,  
Harapan mulya, Medan satria, Bekasi 17143  
021-29601461 / 0851 5520 7890  
sales@vip-equipment.com  
www.vip-equipment.com



#### SAFETY

- Operate safely in accordance with proper operation manual.
- To prevent trouble and accidents, perform daily and preventive maintenance checks without fail.

